

This is an excerpt from the book

# **The Complete Illustrated Guide to Shaping Wood**

by Lonnie Bird

Copyright 2001 by The Taunton Press  
[www.taunton.com](http://www.taunton.com)

# Edge Treatments



**Simple Shaped Edge**

- Shaped Edge with a Handheld Router (p. 136)
- Shaped Edge on the Router Table (p. 136)
- Chamfer with a Block Plane (p. 137)
- A "Worn" Table Edge (p. 137)



**Shaping an Entire Edge**

- Entire Edge Shaped on the Shaper (p. 138)
- Entire Edge of a Curved Shape on the Router (p. 139)
- Entire Edge of a Curved Shape on the Shaper (p. 140)



**Lipped Door Edge**

- Shaping a Lipped Door Edge (p. 141)



**Shaping a Board's Face**

- Face of a Board Shaped on the Shaper (p. 142)



**Dished Tabletop**

- Dished Tabletop (p. 143)

When the edge of a tabletop or drawer front is shaped, it creates the same visual effects as a strip molding. But shaping an edge yields additional benefits; the square corners are removed, the resulting edges are softer to the touch, and the problems of wood movement associated with applied moldings are nonexistent, because the edge is part of the original stock.

Undoubtedly, the simplest edge treatment for tabletops is the roundover. By shaping a small radius on the edges, you remove the hard look and feel of the corner. The effect improves with age as the surfaces wear unevenly, creating a worn look. To create the worn look artificially, you can work the rounded surfaces with a file.

Another attractive table edge is the reverse ogee. The concave-convex profile creates an edge that appears thin and delicate. When designing an ogee edge, you can alter the effect by changing the center-point locations. The possibilities for edge treatments are broad, because router bits and shaper cutters are available in a wide variety of profiles.

➤ See “*Basic Molding Profiles*” on p. 155.

The edges of doors and drawers can also benefit from simple treatments. Adding a bead is a great way to frame the perimeter of flush-fitting doors and drawers. If a veneer is used on the faces, the bead will protect the fragile edges from chipping. You can add the bead after veneering; just cut a shallow rabbet around the drawer perimeter and miter a thin beaded strip.

You can also bead the edges of drawer fronts made from solid stock. The bead can be shaped into the front with a plane, router, or scratch stock. If you choose to shape a bead on the ends and edges, you’ll need to miter the corners with a chisel.

## TABLE EDGES

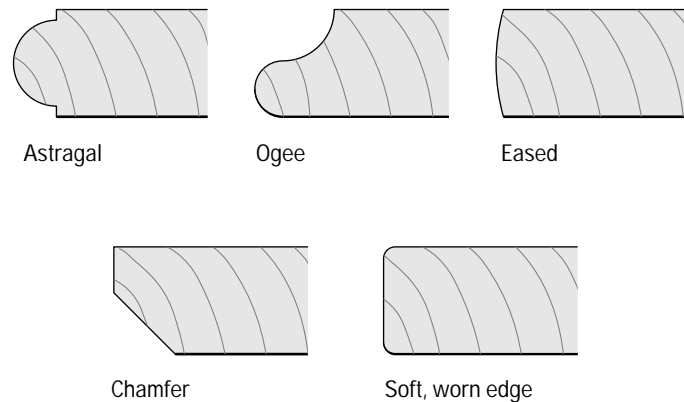

## LIPPED DOORS WITH THUMBNAIL PROFILE

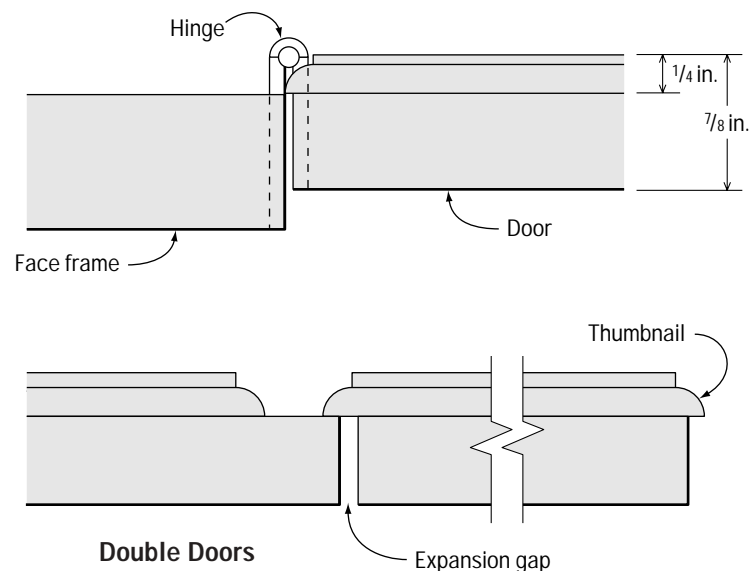

The thumbnail profile is an attractive finish for the edges of doors, drawer fronts, and tabletops.



### LIPPED THUMBNAIL EDGE FOR DOORS AND DRAWERS

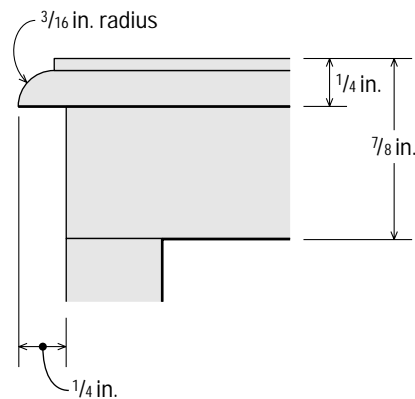

When shaping an edge, a bearing or rub collar rides on the remaining portion of the edge to guide the cutter.



Almost any profile can be used on door and drawer edges. One popular and traditional profile is the thumbnail. It's most commonly used with lipped doors and drawers. A rabbet is cut around the inside perimeter, and the door or drawer front is fit within the opening. The lip that remains is shaped with a thumbnail profile. The result is a door or drawer that covers the opening, yet the edge is thin and refined.

### Shaping the Entire Edge

The most efficient tools for shaping edges are the router table and shaper. Doors, drawers, and smaller tabletops are easy to handle when feeding through the machines. But large, awkward work is easier to shape with a handheld router.

When shaping the edges of round or curved tabletops you'll need to use a bit or cutter with a bearing to guide the cut. If the edge is partially shaped, the bearing can follow the remaining portion of the edge. However, if the entire edge is shaped, you'll need to make a template to guide the cut.

➤ See "*Template Shaping*" on p. 117.

### Dished Tops

Still another form of molded edge treatments is the dished top. The surface of the top is recessed, and the raised rim is molded. If the top is rectilinear, it's simple to add a strip of molding to the edge and miter the corners. But if the top is round, the molding and top are easier to shape as one piece.

Dished tops were popular on eighteenth-century tea tables and candle stands. The traditional method used is to turn the top on

## SHAPING EDGES

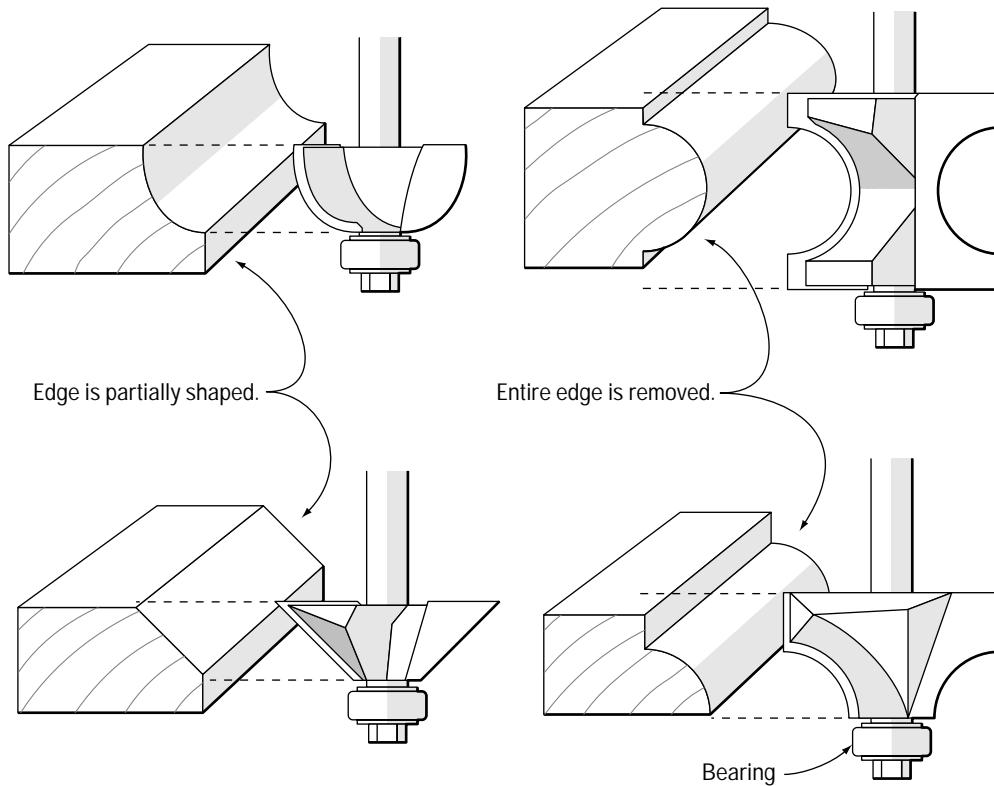

When the entire edge of curved stock is shaped, a template is required to guide the bearing.

a lathe. The molded perimeter and dished interior are both created by turning the top at a slow speed. A floor-stand tool rest is needed to support the tools during the turning process.

These days, a more efficient method for dishing circular tops is with a router. A jig is used to suspend the router over the top, and the router is held stationary while the top is rotated in the jig. A straight bit is used to dish the flat interior, and profile bits are used for the molded edge. Afterward, the interior is scraped and sanded smooth.



A jig allows the router to ride above the work while cutting to a specific depth. This setup creates the depression for a dished tabletop.

## Shaped Edge with a Handheld Router

One of the advantages of a router over a shaper is that it is lightweight and portable. Profiling the edge of large, awkward stock such as a tabletop can be difficult without a helper—but with the router it's a snap. The chamfer shown here is just an example of the many edge treatments you can cut with a router.

First mill the stock to size and clamp it to your workbench. If you're creating a large chamfer, you may want to shape it in two passes. Otherwise, set the bit for the required cutting depth and guide it around the perimeter of the top in a counterclockwise direction. To avoid unsightly tearout on the edges, shape an end first (**A**) and slow the feed rate as you approach the corner. As you finish with the sides (**B**), any slight tearout will be shaped away.

**A****B****A****B****C****D**

## Shaped Edge on the Router Table

The router table has replaced the shaper for most small tasks. Shaping a chamfer with the router table is a prime example.

Begin by adjusting the bit height (**A**) and set the fence tangent to the guide bearing on the bit (**B**). Then, starting with an end, feed the stock from right to left (**C**). When shaping the ends, slow down the feed as you approach the corner to avoid excessive tearout. When you shape the edges, any minor tearout will be shaped away (**D**).

**A****B****C****D**

## Chamfer with a Block Plane

Hand tools are a pleasure to use and are surprisingly efficient, especially when only a few pieces need to be shaped.

First, lay out the chamfer with a pencil to use as a guide while cutting (**A**). A combination square will guide the pencil and keep the layout consistent (**B**).

Next, begin chamfering the stock on the end of the board (**C**). Hold the plane at an angle that corresponds to the desired angle of the chamfer. As you approach the layout lines, you can adjust the angle if needed. Finish the surface with one continuous light pass. Any tearout that occurs will disappear when you chamfer the edges (**D**).

## A "Worn" Table Edge

A worn, rounded surface is friendly to the touch and has a familiar look. Any surface can be worked to create an appearance of age; but the square, utilitarian edges of a tabletop work well for this technique.

First, use a  $\frac{1}{4}$ -in. roundover bit to remove the excess stock on the top and bottom of the edge (**A**). Next, use a coarse file to gently round and soften the corners (**B**). Be careful not to overdo it, or it can look artificial. A light pass with a scraper completes the job (**C**).

**A****B****C**



A



B



C



D

## Entire Edge Shaped on the Shaper

Many attractive edge profiles, such as an ogee, involve shaping the entire edge. When shaping the entire edge, part of the stock width is removed. To compensate for the loss of width, a split fence is used; the outfeed half of the fence is adjusted forward the same amount as the stock being removed. In other words, the outfeed fence must be tangent to the smallest cutting diameter of the cutterhead.

Begin by adjusting the spindle height (A). To make the fence adjustment, first shape enough length of stock to reach the outfeed fence. Now turn the shaper off. Next, turn the micrometer screw on the fence back to advance the fence until it contacts the stock (B). Now lock the fence and make the cut beginning with the end (C). As you approach the corner, slow down the feed to avoid excessive tearout at the edge. Any minor tearout will be cut away as the edge is shaped.

Sometimes the back edge of a top does not need to be shaped. For example, the top of a dressing table that is placed against a wall. In this case, rip the top to final size after shaping to remove any tearout that may have occurred at the back edge (D).

## Entire Edge of a Curved Shape on the Router

Anytime you shape a curved surface with a router, the rub bearing on the bit must follow a curve to guide the bit and limit the cutting depth. When only part of the edge is shaped, the portion that remains can serve to guide the bearing. However, when the entire edge is shaped, a template is needed to guide the cut (A).

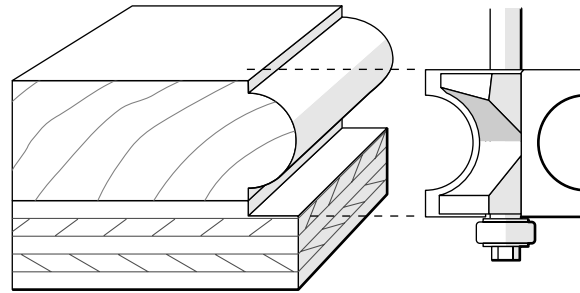

A

Because the entire edge is removed, a template is needed when shaping this profile on a curved surface.

➤ See “*Template Shaping*” on p. 117.

After making the template, trace it onto the workpiece. Now saw the outline slightly proud of the line, which will provide extra stock to be removed by the router bit. If the top is large and your bandsaw is limited in size, you may opt to use a portable jigsaw (B). If so, clamp the work to the bench to keep it stationary while sawing.



B

Next, attach the template to the underside of the top with screws (C). The screw holes will later be hidden, but make certain that the screw doesn't penetrate the full thickness of the top.



C

Before shaping, set the bit height with an offcut from the top (D). Now you're ready to make the cut. To have complete control of routers and shapers, it's important always to feed in the opposite direction of the cutter rotation (E). When hand feeding a router, move it counterclockwise around the top's perimeter.



D



E



A



B



C

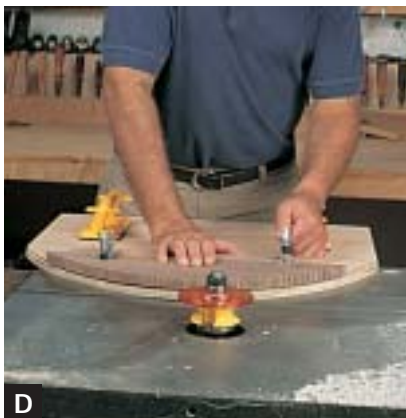

D



E



F



G

## Entire Edge of a Curved Shape on the Shaper

If you own a shaper you'll find it to be a great tool for shaping edges. To shape curved edges, you'll need a rub bearing from the cutterhead manufacturer. You'll also need to construct a template to work in conjunction with the bearing.

Secure the work firmly to the template. Use a guard; keep your hands safely distanced from the cutterhead; and, if possible, extend the template beyond the workpiece. This will give you a smooth entry to the cut, because the template will contact the bearing before the cutterhead contacts the workpiece.

➤ See *"Template Shaping"* on p. 117.

The first step is to carefully set up the shaper. First mount the bearing (A), then the cutterhead (B), and finally the guard. Secure the assembly with a lockwasher and nut (C).

Next, secure the work to the template with a pair of toggle clamps (D) and a single screw (E). The screw holds the work to the template in an area that the clamps can't reach. Because the screw leaves an ugly hole, make sure it's located where it won't appear in the completed work; in this example, a handhold will be cut out in the area of the screw hole. Note, too, that the screw is placed well out of the cutterhead's path.

Start the cut by first positioning the template against the bearing (F). Then feed the stock against the cutterhead rotation (G).



**WARNING** Shapers can be dangerous, especially when used to shape curved stock. Take the necessary precautions.

## Shaping a Lipped Door Edge

Unlike an overlay door that closes against the cabinet face, a lipped door looks refined. That's because most of the door's thickness fits inside the cabinet and the remaining lip is shaped with a delicate thumbnail profile.

The example I'm using here is the pendulum door from the waist of a tall clock. The top of the door has a decorative cutout. After bandsawing the top of the door, use a flush-trimming router bit and a template to remove the bandsaw marks (A). Then carve the inside corners where the router bit didn't reach (B). Next, use a roundover bit to shape the thumbnail profile around the perimeter of the door (C). Set the height of the bit to create a  $\frac{1}{16}$ -in. fillet next to the thumbnail profile. This fillet is important; it creates another fine detail to capture light and create a shadow line.

After the thumbnail, shape the rabbet that allows most of the door to fit within the opening. The bearing on the rabbeting bit can ride along the thumbnail without damaging it; just don't press too hard (D).

---

**[ TIP ]** A fence can be used to limit the rabbet's depth along the straight portions of the door.

---

Afterward, carve the inside corners on the top of the door to complete the thumbnail profile (E).





## Face of a Board Shaped on the Shaper

Whenever you shape the face of a board on the shaper, it's necessary to mill the stock oversize in width. As the stock passes the cutterhead a portion of the original face remains intact to provide a reference surface on the outfeed fence.

The example shown here is a skirt from a tea table (A). The face of the skirt is a contoured molding strip that matches the knee of the leg to which it joins.



To provide stability, use a featherboard to keep the stock firmly in position against the fence. Note that the featherboard is mounted on a wood block to raise it off of the table (B). This provides pressure in the area that remains intact. After shaping, rip the molded skirt free from the stock (C).



## Dished Tabletop

A dished tabletop has a molded rim that sets slightly above the rest of the table surface (A). The molding is small and refined and the effect is dramatic as it reflects light and casts shadows. The design is a classic one but the router technique for producing it is relatively new. The router is suspended over the top, which rotates on a hub. To use the technique you'll first have to build a jig.

**[TIP]** A one-board top looks best; but if you must use two boards, take care when matching the grain and color.

Begin by milling the stock for the top. Now draw the radius of the top (B). Next bandsaw the top perimeter and glue the hub to the center (C). If you sandwich a layer of heavy paper between the top and the hub, it is much easier to remove the hub after the process is complete.

After the glue has dried, mount the top into the jig (D). Before shaping the molding, it's necessary to true the edge of the top. A spiral straight bit cuts cleaner and with less chatter than an ordinary straight bit (E).

Once the bit is mounted, you're ready to begin. Never attempt to start the router when the bit is in contact with the stock. Instead, start the router, slide it along the rails until it touches the top, clamp the router in position, and rotate the top. Always rotate the top clockwise against the bit rotation (F).

Next, switch to the roundover bit to create the bead. If you're not able to find a bit without a bearing it's easy to remove the bearing and grind away the bearing stud. To adjust the bit depth, use a block of plywood from the jig (G).

*(Text continues on p. 144.)*

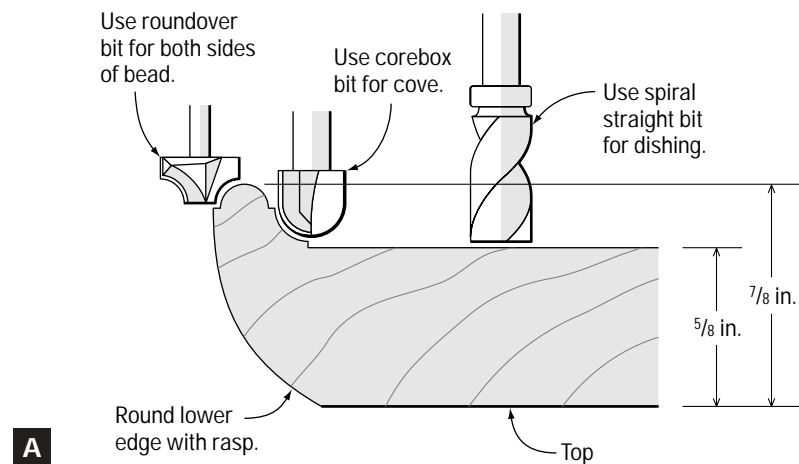



G



H



I



J



K



L

Shaping the molding is much the same as truing the perimeter: Start the router, clamp it in position, and rotate the top (H). To ensure that the molding isn't squeezed, begin from the outside edge and work inward (I). The molding is shaped in three steps: outside edge of bead; inside edge of bead; and cove, which is shaped with a bull-nose bit.

Once the molding is complete, switch back to the straight bit to dish the top (J). This process goes quickly, because there is no careful positioning of the router as there was with the molding. If you have a helper, one of you can hold the router while the other rotates the top, which sidesteps the process of clamping the router for each cut.

With the router work completed, you're ready for the handwork. Clamp the top to the bench and scrape the surface smooth (K). Use care to avoid scarring the molding. After smoothing the top, the edge will need shaping along the underside to remove the square corner. This step also gives the top a thin, refined appearance. A rasp works well for this process, but first draw a line with a compass for use as a guide. Now secure the top in the vise and rasp the edge (L). Work the surface from the fillet at the bead to the layout line. When you're satisfied, smooth the edge with a file, scraper, and then sandpaper.



**WARNING** A dust collector is a must. Otherwise this process produces a choking cloud of fine dust and chips.